

TROPHYLITE R-8

TROPHYLITE has been a leader in spec truck off-road racing. Now the TROPHYLITE family is growing with a big sister. We are proud to announce the next generation of spec off-road truck racing, the TROPHYLITE R-8. The TROPHYLITE R-8 is an all new CAD Designed spec class truck with a sealed and tagged V-8 engine program to carry race teams into some of the most competitive racing without breaking the bank. Here are the specs for the new truck.

Full Turn Key Packages from: \$94,900 base price

Main Chassis:

All 4130 Chromalloy tubes with 2" main cage section (smaller tubes where they can be used)
TIG welded and fully CAD designed
125" Wheel base
85" wide rear track width
85" wide front track width
Front suspension built on 5' rake
37" General Grabber Tires
17" bead lock Method Race wheels
2 spare tire mounts on the rear
70 gallon fuel cell
3" fuel fill neck
Large fuel vent line for fast filling
Mastercraft 3G seats
Fiberglass body work to match engine
Fiberglass dash shell
Large aluminum radiator mounted in rear
Full aluminum panels
Large canister air filter
An plumbing
Wilwood brake pedal and master cylinders

Front Suspension:

A-Arms with 24" of wheel travel
All Chromalloy parts all TIG welded

Large spindles and 7075 Aluminum hubs
Large Wilwood brakes and vented rotors

Rear Suspension:

Trailing arm 4-link with 32" of wheel travel
9" style fully fabricated Currie F-9 full floating rear end housing
7075 Aluminum hubs with 2" axles
Large Wilwood brakes and vented rotors
9" center section with spool
Large spindle and bearing assembly

Shocks:

3" coil over with dual rate springs
By-pass shock with 3 compression and 2 rebound tubes

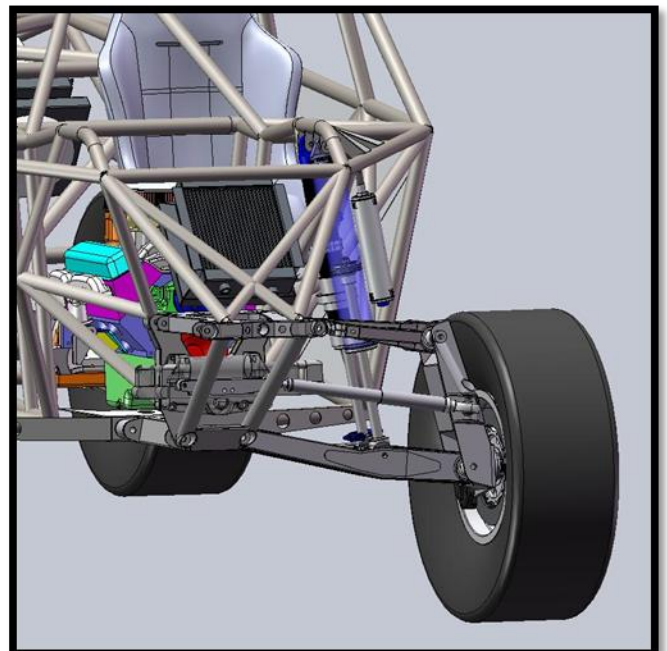
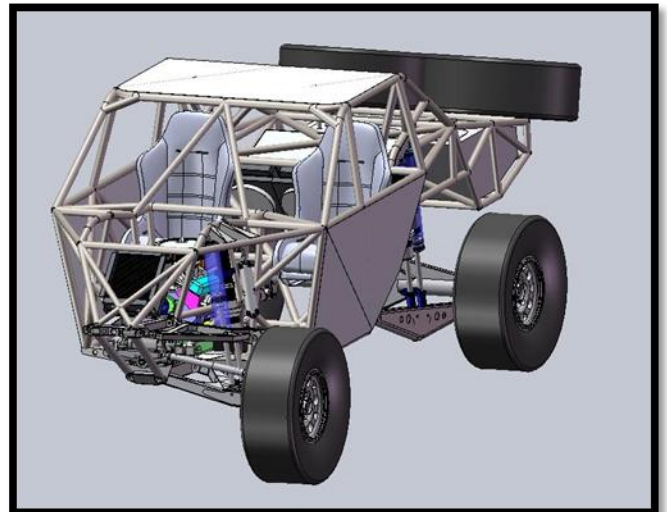
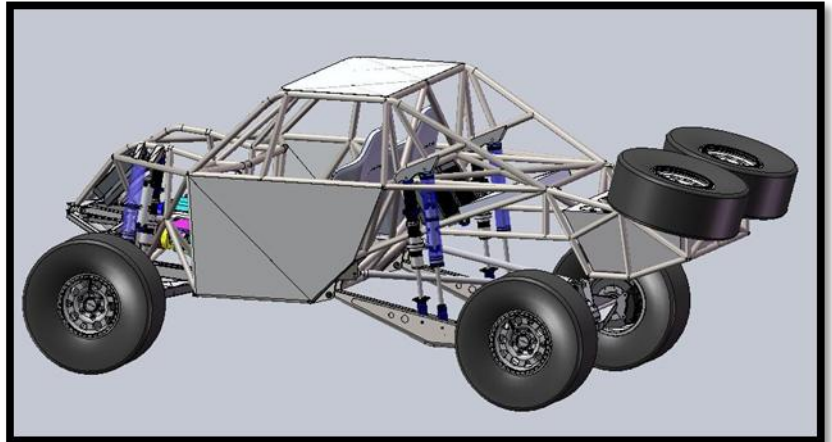

Steering:

HOWE big 3" rack and pinion with servo
Custom matched tie rod and mount set to match chassis
Large outer heims for long life
Matched for no bump steer

Power train:

Your choice of Ford or Chevy power plants
Ford – 6.2L fuel injected engine sealed and tagged
Chevrolet - LS3 fuel injected engine sealed and tagged
450 HP sealed engine program to keep costs down
Turbo 400 transmission with spec torque converter and
billet tail housing
sealed computers to eliminate modifications
Dual aluminum transmission coolers with fan
Large aluminum oil cooler with fan
Spec headers and exhaust

Options:

Communication packages for radio and intercom
GPS units
Race Pack style digital dash option
KC HiLites light bar
Aluminum jack system and mounts
Special V-6 package for a Class-6 or Class 7200
Wiring upgrades with many options
Plumbing system upgrades for Kevlar hoses
Multiple spares, wheels, driveline
Dual batteries and switch
Tool bags and mounts
Spare fluids mounts

***The TROPHYLITE R-8 will be added to the full
General Tire TROPHYLITE race series for 2011.
Now accepting orders for the new trucks for first
deliveries in November.***

For more information contact

Greg Foutz

gregf@trophylite.com

480-633-3010

